

EVERPURE® claris™ GEN2 3/8" QCF HEAD

DESIGNED EXCLUSIVELY FOR USE WITH CLARIS REPLACEMENT CARTRIDGES

Clariss Gen2 3/8" QCF Head: EV4339-92



APPLICATIONS

Coffee and Espresso
Hot Drink Vending
Combi Steamers and Self-Cooking Systems

Steam Cookers and Ovens
Brewed Iced Tea

FEATURES • BENEFITS

Commercial-quality filter head is designed exclusively to fit Claris filter cartridges

Solid, durable construction is ideal for foodservice and vending applications

Engineered for durability, strength and longevity

Corrosion-resistant hardware

Tamper proof bypass settings

HEAD FEATURES:

Fast change-out - locks with only a 45° turn

Built-in flush port

Auto shut-off

Quick and easy adjustable bypass; key provided

INSTALLATION TIPS

The system can be operated freestanding, lying horizontally or mounted vertically.

If mounted vertically to a wall, securely connect the mounting bracket to the wall using suitable screws.

Water pressure at the filter system inlet must not exceed 116 psi (8 bar). A pressure reducer valve must be installed on the water supply side of the filter system if the inlet pressure exceeds 116 psi (8 bar).

Shut-off valve must be installed upstream of the filter.

Refer to Installation, Operation & Maintenance Manual for cartridge flushing and startup.

OPERATION TIPS

Change Claris Cartridge when its pre-calculated water volume has been reached or at least once a year.

Change cartridges when capacity is reached.

Always flush the filter cartridge at time of installation and cartridge change.

Do not use hardness test strips to check for hardness reduction, please use titration kit to check for hardness reduction.

EVERPURE® claris™ GEN2 3/8" QCF HEAD

EV4339-92

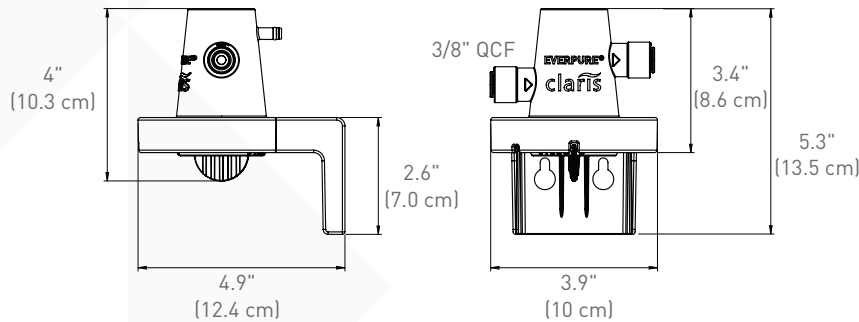

SPECIFICATIONS

Overall Dimensions:

5.3" H x 3.9" W x 4.9" D
(13.5 cm x 10 cm x 12.4 cm)

Electrical Connection:

None required

Claris™ is a trademark of Aquis, GmbH

WARRANTY

Everpure Claris water treatment systems by Pentair® are covered by a limited warranty against defects in material and workmanship for a period of one year after date of purchase. Everpure replaceable elements (filter cartridges and water treatment cartridges) are covered by a limited warranty against defects in material and workmanship for a period of one year after date of purchase. See printed warranty for details. Pentair will provide a copy of the warranty upon request.



WATER QUALITY SYSTEMS

EVERPURE-SHURFLO WORLD HEADQUARTERS, 1040 MUIRFIELD DRIVE, HANOVER PARK, IL 60133 USA • FOODSERVICE.PENTAIR.COM
800.942.1153 MAIN (US ONLY) • 630.307.3000 MAIN • 630.307.3030 FAX • CSEVERPURE@PENTAIR.COM EMAIL

EVERPURE-SHURFLO AUSTRALIA, 1-21 MONASH DRIVE, DANDENONG SOUTH, VIC 3175, AUSTRALIA
011.1300.576.190 TEL • 011.61.39.562.7237 FAX • AU.EVERPURE@PENTAIR.COM EMAIL

EVERPURE-SHURFLO CHINA, 21F CLOUD 9 PLAZA, NO 1118, SHANGHAI, 200052, CHINA
86.21.3211.4588 TEL • 86.21.3211.4580 FAX • CHINA.WATER@PENTAIR.COM EMAIL

EVERPURE-SHURFLO INDIA, GREEN BOULEVARD, B-9/A, 7TH FLOOR - TOWER B SECTOR 62, NOIDA - 201301
91.120.419.9444 TEL • 91.120.419.9400 FAX • INDIACUSTOMER@PENTAIR.COM EMAIL

EVERPURE-SHURFLO EUROPE, PENTAIR WATER BELGIUM BVBA, INDUSTRIEPARK WOLFSTEE, TOEKOMSTLAAN 30, B-2200 HERENTALS, BELGIUM
+32.(0).14.283.504 TEL • +32.(0).14.283.505 FAX • SALES@EVERPURE-EUROPE.COM EMAIL

EVERPURE-SHURFLO JAPAN INC., HASHIMOTO MN BLDG. 7F, 3-25-1 HASHIMOTO, MIDORI-KU, SAGAMIHARA-SHI KANAGAWA 252-0143, JAPAN
81.(0)42.775.3011 TEL • 81.(0)42.775.3015 FAX • INFO@EVERPURE.CO.JP EMAIL

EVERPURE-SHURFLO SOUTHEAST ASIA, SOUTHEAST ASIA, 390 HAVELOCK ROAD, #04-01, KING'S CENTRE, SINGAPORE 169662
65.6768.5800 TEL • 65.6737.5149 FAX • CSEVERPURE@PENTAIR.COM EMAIL

All Pentair trademarks and logos are owned by Pentair, Inc. or its affiliates. All other registered and unregistered trademarks and logos are the property of their respective owners. Because we are continuously improving our products and services, Pentair reserves the right to change specifications without prior notice. Pentair is an equal opportunity employer.