

CGS-20 EV9100-20

COSTGUARD CGS-20 FILTERS APPLICATIONS AND FEATURES

These filters can be used for post mix, coffee, and ice applications. The economical Costguard filters trap much of the dirt which contributes to scale buildup in ice makers, and clogs the delicate orifices of other water-using equipment.** By selecting the appropriate cartridge, your Costguard filter can reduce cysts, bad tastes and odors, and particulate for ingredient water.

- Taste and Odor Reduction
- Sediment Reduction (CGS-20/CG53 only)
- Scale Reduction**
- Fine Filtration (CGS-20/CG53 only)
- Cyst (CGS-20/CG53 only)

NOTE: The housing does not contain a filter cartridge. Choose the appropriate cartridge for your needs and install in housing according to the cartridge replacement instructions before proceeding with installation. See Cartridge Selection Guide.

CARTRIDGE SELECTION GUIDE

Product Name	Part Number	Cyst	Taste & Odor	Sediment	Scale**	Filter Life/gallon	Flow Rate/gpm
CG53-20	EV9108-63	X	X	X		20,000	4.0
CG53-20S	EV9108-67	X	X	X	X	20,000	4.0
CG5-20	EV9108-25		X	X**		12,000	3.34
CG5-20S	EV9108-27		X	X**	X	12,000	3.34

** Not Performance Tested or Certified by NSF.

SPECIFICATIONS

High impact plastic head and bowl. Head has 3/8" female threads for inlet and outlet pipe connections. Protect filter bowl from pesticide sprays and freezing. Intended for indoor use only.

NOTE: To assure proper performance of this filter it is recommended to replace your sump housing at least every 10 years.

Flow rate: See Performance Data Sheet for specific flow rates.

Pressure: 30-125 psig (0.9 - 8.62 bar), non-shock†

Temperature: 40-100°F (4.4-37.8°C) Cold water use only.

Unit dimensions: 9.25" wide x 25" high x 5.25" deep (23 x 64 x 13 cm); a clearance of 2" (5 cm) underneath is required for cartridge exchange

Cartridge length: 19.75" (50 cm)

Connections: 3/8" internal pipe thread (FPT)

† If pressure exceeds 125 psi non-shock, use appropriate pressure regulators.

PARTS LIST

Key	Description	Part #
	Pressure Relief Button Kit	EV3092-54
#237 Slimline™	O-Ring	EV3092-56
#20 Slimline™	White Sump (Bowl)	EV3093-32
SW-1	Wrench	EV3092-59
	Pressure Gauge	EV3094-40

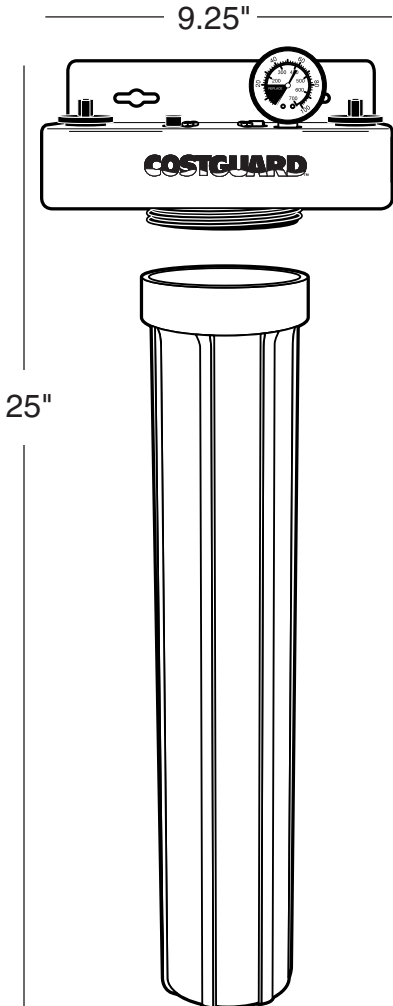

Mounting Depth 5.25"



The CGS-20 with cartridges CG53-20, CG53-20S, CG5-20 and CG5-20S is Tested and Certified by NSF International to NSF/ANSI Standards 42&53. See performance data sheet in manual for specific claims.

INSTALLATION

The Costguard filter (part number EV9100-20) has 3/8" FPT connections. Before starting installation, be sure to shut off both power and water to the equipment being served by your CostGuard system. For servicing purposes, a manual shut-off valve should be installed in the water line.

IMPORTANT: Always use Teflon® tape at all thread connections.

1. Select a suitable location for mounting the prefilter and install mounting screws 4-3/4" apart. The system should be close to the machine served.
2. Separate the bowl and head assembly. Set the bowl and cartridge aside.
3. Check to be sure the o-ring on the bowl is sufficiently lubricated. If additional lubrication is needed, use only a high quality grade of silicone grease.
4. Position the cartridge on the guide seat in the bottom of the bowl. Then screw the bowl onto the head, by hand; do not use a housing wrench!
5. Connect the water line to the inlet of the filter. (Use 3/8" minimum piping on filter to assure adequate flow of water). Connect outlet side to the next piece of equipment used.
6. Turn on the water to the filter and press the red button on the head to open the pressure relief valve, purging air from the system. When water begins coming through the pressure relief valve, release the button. Inspect the filter assembly for leaks. Your system is now in service. Always keep a supply of replacement cartridges on hand.

NOTE: The drinking water cartridge may contain carbon fines (very fine black powder). After installation, flush cartridge for 5 minutes to remove the fines before using the water.

CARTRIDGE CHANGE

Replace filter cartridges when they become excessively dirty, when the pressure gauge after the filter indicates extremely low pressure during water flow, or when changes in taste and odor are detected.

1. Turn off inlet and outlet water valves and press the pressure relief valve.
2. Unscrew the bowl from the filter head, remove the used cartridge and empty the water from the bowl.
3. If the o-ring on the bowl feels dry, lubricate it with a high quality silicone grease.
4. Clean the bowl with a mild solution of unscented dishwashing detergent. DO NOT use soap, strong or scented detergents, chemical cleansers or abrasives.
5. Position the replacement cartridge on the guide seat in the bottom of the bowl. Then firmly screw the bowl into the head by hand. DO NOT USE A HOUSING WRENCH. Flush cartridge for 5 minutes to remove carbon fines before using the water.

CAUTION: The o-ring provides a water tight seal. Make sure the o-ring is properly seated and lubricated.

CARE AND CLEANING

For the protection of your filter, do not store open containers of oils, alcohols, insecticides, polishes, cleaning fluids or other common household chemicals near your filter installation. To maintain the clear, bright appearance of the filter bowl, clean only with mild solution of unscented dishwashing detergent. Do not clean with soap, strong or scented detergents, chemical cleansers or abrasives.

Check the system and installation for compliance with your state and local laws and regulations. For cold water use only.

⚠ WARNING: Do not use with water that is microbiologically unsafe or of unknown quality without adequate disinfection before or after the system. Systems certified for cyst reduction may be used on disinfected waters that may contain filterable cysts.

Warranty of COSTGUARD Filter Housings

This warranty applies to the Filter Housing. It does NOT apply to any disposable filter cartridge where life expectancy varies with the water being filtered. This warranty covers defects in material and workmanship only for five full years from the original date of delivery. COSTGUARD will replace any part which in COSTGUARD's opinion is defective, unless: (1) any part of the unit has been subjected to any type of tampering, alteration, or improper use after delivery, or (2) it has been repaired by anyone not approved by COSTGUARD. Our Obligation does not include the cost of shipment of materials. COSTGUARD is not responsible for damage in transit, and claims for such damage should be presented to the carrier by the customer.

This product has been designed solely for use as a housing for a disposable filter cartridge. It is NOT warranted against freezing, and neither this product nor its parts are warranted against defects or deterioration caused by uses for which this product was not expressly intended.

THE FOREGOING WARRANTY IS EXCLUSIVE AND IN LIEU OF ALL OTHER WARRANTIES, EXPRESSED OR IMPLIED, WHETHER ORAL OR ARISING BY USAGE OF TRADE OR COURSE OF DEALING, INCLUDING, WITHOUT LIMITATION, ANY WARRANTIES OF FITNESS OR MERCHANTABILITY. THIS WARRANTY IS THE PURCHASER'S SOLE AND EXCLUSIVE REMEDY, IN NO EVENT SHALL COSTGUARD BE LIABLE FOR ANY ANTICIPATED OR LOST PROFITS, INCIDENTAL DAMAGES, CONSEQUENTIAL DAMAGES, COSTS, TIME CHARGES OR OTHER LOSSES, WHETHER BASED ON BREACH OF CONTRACT, TORTIOUS CONDUCT OR ANY OTHER THEORY, INCURRED IN CONNECTION WITH THE PURCHASE, INSTALLATION, REPAIR OR OPERATION OF THE FILTER HOUSING. COSTGUARD DOES NOT AUTHORIZE ANYONE TO ASSUME FOR IT ANY LIABILITY OR TO MAKE ON ITS BEHALF ANY ADDITIONAL WARRANTIES IN CONNECTION WITH THE FILTER HOUSING OR ANY PART THEREOF.

For servicing under this warranty, return any defective part to YOUR DEALER within the five year period referred to above.

PERFORMANCE DATA

Important Notice: Read this Performance Data Sheet and compare the capabilities of this system with your actual water treatment needs. It is recommended that, before installing a water treatment system, you have your water supply tested to determine your actual water treatment needs.

This system has been tested according to NSF/ANSI 42 and 53 for the reduction of the substances listed below. The concentration of the indicated substances in water entering the system was reduced to a concentration less than or equal to the permissible limit for water leaving the system, as specified in NSF/ANSI 42/53.

Do not use with water that is microbiologically unsafe or of unknown quality without adequate disinfection before or after the system. Systems certified for cyst reduction may be used on disinfected waters that may contain filterable cysts.

Model CGS-20 Substance	Influent Challenge Concentration	Max. Permissible Product Water Concentration	Reduction Requirements	Average Reduction
CG53-20/CG53-20S Cartridge				
Standard 42: Aesthetic Effects				
Chlorine	2.0 mg/L±10%		≥50%	97%
Particulates (0.5–<1µm) Class I	at least 10,000 particles/mL		≥85%	99%
Standard 53: Health Effects				
Cysts ²⁾	Minimum 50,000/L		99.95%	99.99%
Turbidity	11 ± 1 NTU	0.5 NTU		>95%
Flow Rate: 4.0 gpm (15.2 Lpm)				
Capacity: 20,000 gallons (75,700 L) or 12 months				
CG5-20/CG5-20S Cartridge				
Standard 42: Aesthetic Effects				
Chlorine	2.0 mg/L±10%		≥50%	87%
Flow Rate: 3.34 gpm (12.6 Lpm)				
Capacity: 12,000 gallons (45,400 L) or 12 months				

²⁾Based on the use of microspheres. Testing was performed under standard laboratory conditions, actual performance may vary.



The CGS-20 with CG53-20 and CG53-20S cartridges are Tested and Certified by NSF International to NSF/ANSI Standard 42 for the reduction of Taste & Odor, Aesthetic Chlorine, and Particulate. Standard 53 - Cyst and Turbidity Reduction. CGS-20 with CG5-20 and CG5-20S cartridges are Tested and Certified by NSF International to NSF/ANSI Standard 42 for the reduction of Taste & Odor, and Aesthetic Chlorine.

OPERATING REQUIREMENTS

Pressure Range: 30–125 psi (2.1–8.62 bar)

Temperature Range: 40–100°F (4.4–37.8°C)

Turbidity: 5 NTU Max.

TEST CONDITIONS

Flow Rate: As noted for each individual cartridge

Inlet Pressure: 60 psi (4.1 bar)

Water Temperature: 68°±5°F (20°±2.5°C)

Water pH: 7.5±1

Installation instructions, parts and service availability, and standard warranty are inclosed with the product when shipped.

This drinking water system must be maintained according to manufacturer's instructions, including replacement of filter cartridges. Replace cartridges when capacity is reached, or when flow becomes too slow, but at least annually.

For Sales, Parts and Service Contact Your Local Costguard Dealer or:



1040 Muirfield Drive
Hanover Park, IL 60133 USA
Phone: (800) 323-7873
Fax: (800) 942-0081